

Withings Body

Weight & Body Composition - Daily Report
Installation and Operating Instructions (Android users)



Table of Contents

Minimum Requirements	4
Internet access	4
Smartphone or device.....	4
OS version	4
Withings Health Mate® app version.....	4
Withings Body Description	5
Overview	5
Box contents.....	5
Product description	6
Scales screens description.....	6
Setting Up the Withings Body	7
Installing the Withings Health Mate® app	7
Installing your Withings Body	7
Customizing Your Withings Body	18
Changing the configuration of your Withings Body	18
Changing the settings of your Withings Body	21
Using Your Withings Body	29
Tracking your weight and body composition.....	29
Checking the Weather.....	34
Linking Your Account to Partner Apps.....	35
Linking your account to MyFitnessPal	35
Linking your account to Nike+	37
Syncing Your Data.....	40
Dissociating Your Withings Body	41
Performing a Factory Reset of Your Withings Body	43
Cleaning and Maintenance.....	44
Cleaning your Withings Body.....	44
Changing the batteries	44
Installing the carpet feet.....	45

Updating your Withings Body	46
Technology Description	48
Weight.....	48
Body Composition	48
Specifications.....	49
User Guide Copyright.....	51
Safety Instructions.....	51
Use and Storage	51
Location.....	51
Personal Data	51
Service and Maintenance	52
Document Release Overview	53
Warranty.....	54
Regulatory Statements	55

Minimum Requirements

Internet access

Access to the Internet is required to:

- Download the Withings Health Mate® app,
- Set up your Withings Body,
- Upgrade your product whenever an update is available.

For more details, refer to [“Specifications” on page 49](#).

We recommend using the app on a device connected to the Internet to enjoy all features.

Smartphone or device

An Android device (with operational Bluetooth and Wi-Fi or 3G/4G) is required to:

- Set up your Withings Body,
- Retrieve data from your Withings Body,
- Access specific functions of your Withings Body.

Bluetooth Low Energy (BLE) compatibility is recommended to install your Withings Body.

For more details, refer to [“Specifications” on page 49](#).

OS version

You need version 4.3 or above to install and run the Withings Health Mate® App.

Withings Health Mate® app version

We recommend that you use the latest available version of the Withings Health Mate® app to have all the latest features available.

Withings Body Description

Overview

The Withings Body allows you to easily track your weight and monitor your progress. Additionally, it calculates your fat mass, muscle mass, bone mass and water mass by bioelectric impedance to inform you about your body composition.

Of course that's not all your Withings Body does. If you activate the Weather screen, you also get your daily weather report everytime you weigh in.

Because the Withings Body is a connected scale, its true potential is achieved when you use it along with the Withings Health Mate® app. Beside allowing you to install your scale, the Withings Health Mate® app allows you to customize its display, to set a weight goal, and to check the entire history of your weight data.

Thanks to its in-app activity tracking feature and the numerous partner apps you can connect it to, the Withings Health Mate® app helps you reach your weight goal faster by helping you track your activity and check your calorie balance.

Box contents

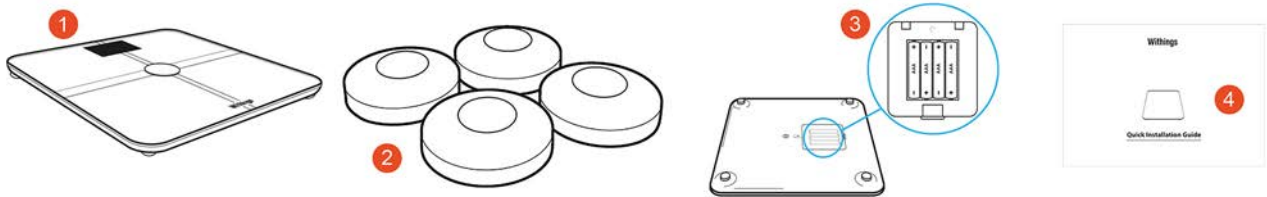

(1) Withings Body

(2) Carpet feet

(3) Batteries (inserted)

(4) Quick Start Guide

Product description

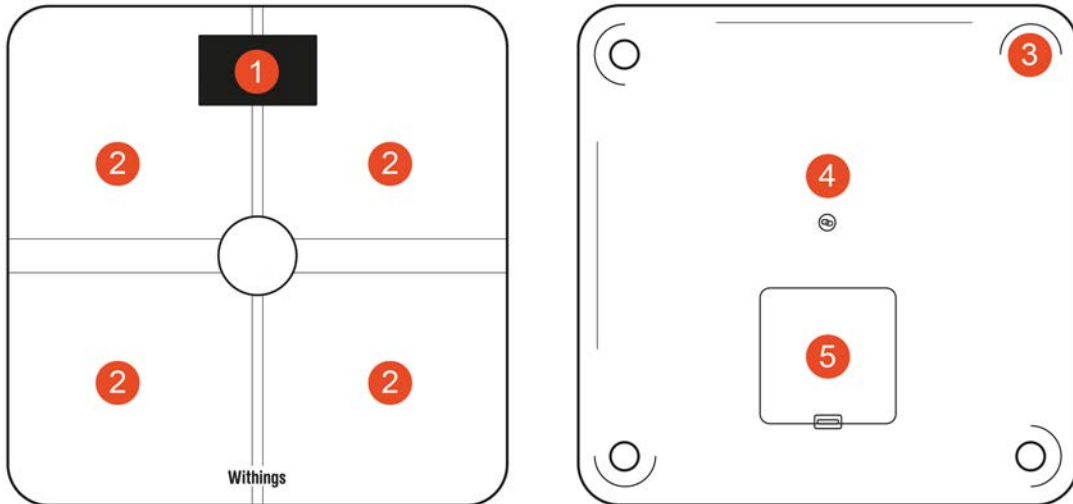

- (1) Display (2) Electrodes (3) Feet
(4) Pairing and units button (5) Battery compartment

Scales screens description

You can select a number of screens to be displayed on your Withings Body:

- Weight: Displays your weight. This screen cannot be disabled.
- Fat Mass: Displays your percentage of fat mass.
- Water: Displays your percentage of water.
- Bone mass: Displays the weight of your bones.
- Muscle mass: Displays the weight of your muscles.
- Weather¹: Displays the weather for the day.
- Weight Trend¹: Displays a graph with your last 8 weight measurements.
- Steps^{1,2}: Displays the number of steps you did the previous day.
- NikeFuel^{1,3}: Displays the amount of NikeFuel you earned the previous day.

You can disable or change the order of these screens as you like after you install your Withings Body. Otherwise, they will appear in the default order.

Refer to [“Changing the screen order”](#) on page 22 for more information.

¹ This screen can only be used if you set up your Withings Body in Wi-Fi

² You either need to own a Withings® tracker, or to use the in-app tracking of the Withings Health Mate® app to display your number of steps on this screen. If you don't have a Withings® tracker, tap the Activity widget at the top of your Timeline in the Withings Health Mate® app and tap **Activate now**. Your mobile device will then start tracking your steps.

³ You need to have a Nike+ account to see the amount of NikeFuel you have on this screen.

Setting Up the Withings Body

Installing the Withings Health Mate® app

If the Withings Health Mate® app is not already installed on your device, perform the following steps:

1. Type go.withings.com in your device's web browser.
2. Tap **Android App on Google play**.
3. Tap **INSTALL**.
The installation process starts.

Installing your Withings Body

Overview

Installing your Withings Body in Wi-Fi gives you access to all the features and screens available. Installing your Withings Body in Bluetooth limits the features and screens available. For example, you can't use the Weather screen and the Steps screen, as they require access to the Internet.

You can change the configuration of your Withings Body anytime you want. Refer to “[Changing the configuration of your Withings Body](#)” on page 18 for more information.

Note that once you've installed your Withings Body on your account, all the users of the account can use it. You are also free to install it on various account. There is, however, a limit of eight users per scale at the moment.

Installing your Withings Body without an existing account

1. Pull the tab out of the battery compartment if it's the first time you install your Withings Body.

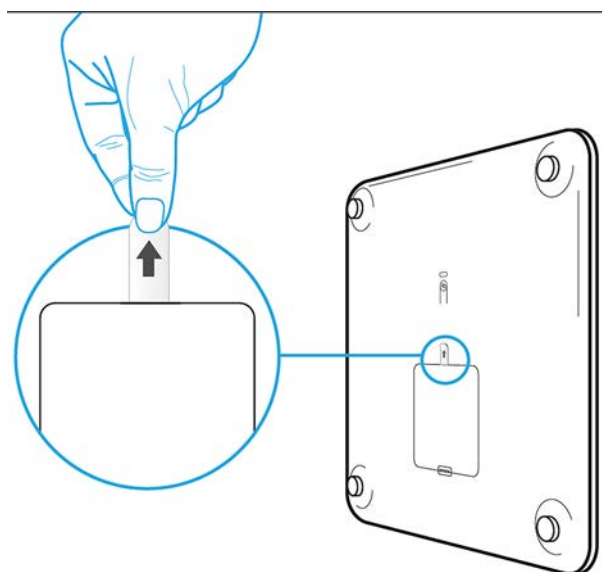

2. Open the Withings Health Mate® app.
3. Tap **Join Withings**.



4. Tap **I'm setting up my device**.

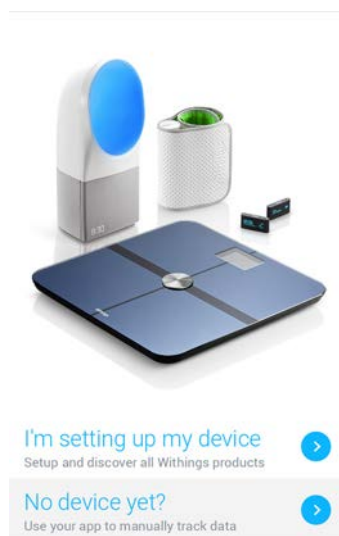

5. Tap **Body**.

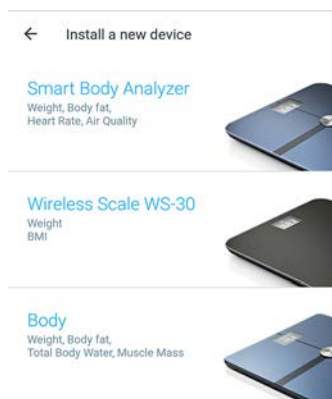

6. Tap **Install**.



7. Press the pairing button at the back of the scale for three seconds and tap **Next**.

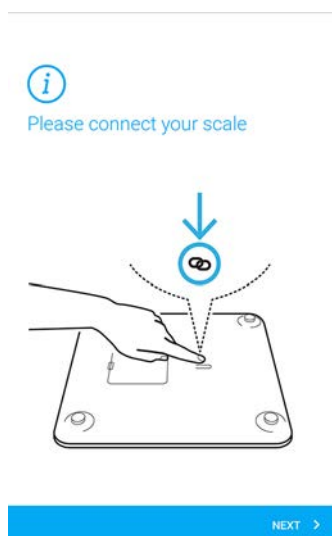

The scale displays a message prompting you to open the Withings Health Mate® app.

8. Tap the Withings Body you want to install.
It may take up to a minute for your scale to be detected by your mobile device.
9. Tap **Pair** to pair your Withings Body with your device.
10. Tap **Next**.



11. Enter your email address, password, and then confirm your password. Tap **Next**.
12. Enter your first name, surname (last name) and birthday. Tap **Next**.
13. Select your gender and enter your current height and weight. Tap **Create**.
This information is necessary for the calculation of your BMI.
It also allows your Withings Body to recognize you based on your weight the first time you weigh in.

14. To install your scale in Wi-Fi, perform the following steps:

a. Tap **Set up Wi-Fi connection**.



b. Tap the Wi-Fi network you want to use or tap **Manual configuration**.

c. Enter the password of the Wi-Fi network.

d. Tap **Next**.

You will need to update the Wi-Fi configuration if you change the network name or password. Refer to [“Changing the configuration of your Withings Body” on page 18](#) for more information.

15. To install your scale in Bluetooth, tap **I don't have a Wi-Fi Network**.



16. Tap **Done**.



The Withings Health Mate® now prompts you to select your target weight. Tap **Cancel** if you don't want to set a weight goal. You can set one later on if you change your mind. Refer to ["Changing your weight goal"](#) on page 31 for more information.

Installing your Withings Body with an existing account

1. Pull the tab out of the battery compartment if it's the first time you install your Withings Body.

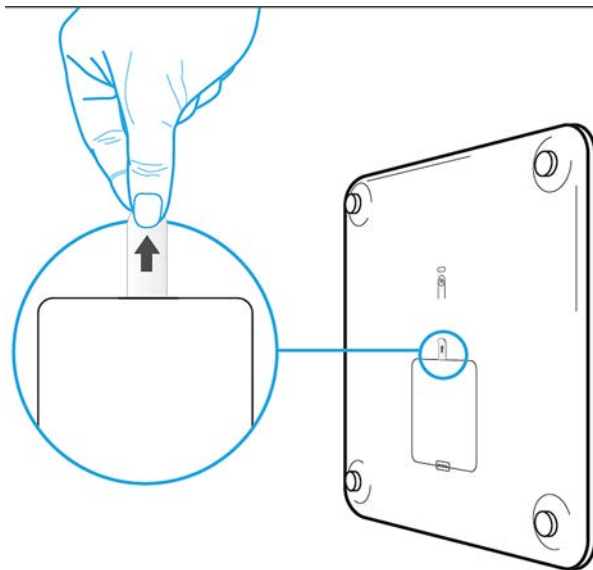

2. Open the Withings Health Mate® app.
3. Go to **My devices**.

4. Tap **+**.



5. Tap **Body**.



6. Tap **Install now**.



7. Press the pairing button at the back of the scale for three seconds and tap **Next**.

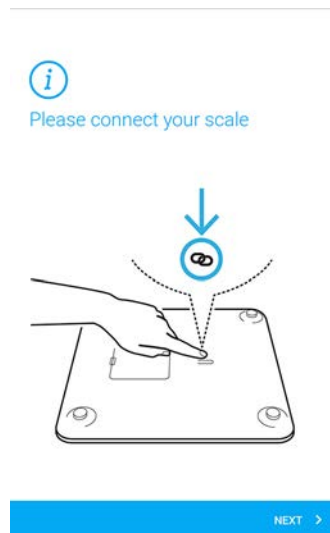

The scale displays a message prompting you to open the Withings Health Mate® app.

8. Tap the Withings Body you want to install.
It may take up to a minute for your scale to be detected by your mobile device.
9. Tap **Pair** to pair your Withings Body with your device.
10. Tap **Next**.



11. To install your scale in Wi-Fi, perform the following steps:

a. Tap **Set up Wi-Fi connection**.



b. Tap the Wi-Fi network you want to use or tap **Manual configuration**.

c. Enter the password of the Wi-Fi network.

d. Tap **Next**.

You will need to update the Wi-Fi configuration if you change the network name or password. Refer to [“Changing the configuration of your Withings Body” on page 18](#) for more information.

12. To install your scale in Bluetooth, tap **I don't have a Wi-Fi Network**.



13. Tap **Done**.



The Withings Health Mate® now prompts you to select your target weight.

Selecting your weight goal

To select your weight goal, perform the following steps:

1. Tap and slide up or down to select your target weight.



2. Tap **Next**.
3. Tap and slide up or down to select the pace at which you want to achieve your weight goal.

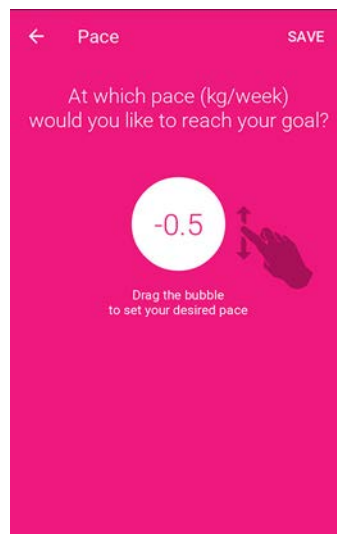

4. Tap **Save**.

Customizing Your Withings Body

Changing the configuration of your Withings Body

You may need to change the configuration of your Withings Body:

- If you want to use a different Wi-Fi network,
- If you've changed the name or password of the Wi-Fi network you use,
- If you want to switch to a Wi-Fi configuration,
- If you want to switch to a Bluetooth configuration.

To change your configuration, perform the following steps:

1. Open the Withings Health Mate® app.
2. Go to **My devices**.
3. Tap **Body**.



4. Tap **Wi-Fi Configuration**.

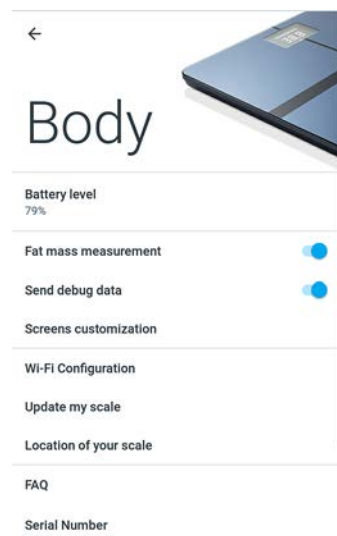

5. Press the pairing button at the back of the scale and tap **Next**.

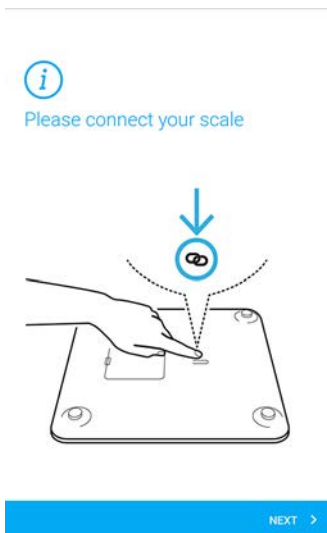

The scale displays a message prompting you to open the Withings Health Mate® app.

6. Tap the Withings Body you want to install.
It may take up to a minute for your scale to be detected by your mobile device.
7. Tap **Pair** to pair your Withings Body with your device.
8. Tap **Next**.



9. To switch to a Wi-Fi configuration or to update the Wi-Fi network:
a. Tap **Set up Wi-Fi connection**.



- b. Tap the Wi-Fi network you want to use or tap **Manual configuration**.
c. Enter the password of the Wi-Fi network.
d. Tap **Next**.

10. To switch to a Bluetooth configuration, tap **I don't have a Wi-Fi Network**.

11. Tap **Done**.

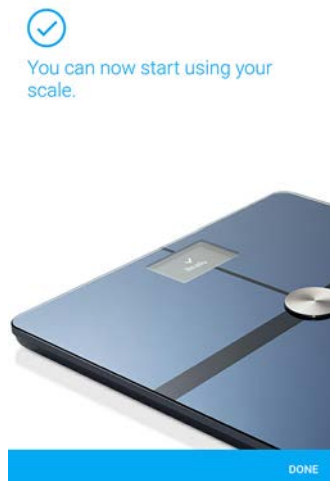

Changing the settings of your Withings Body

Changing the weight unit

You have the choice between three weight units: kilogram (kg), stone (stlb) and pound (lb). To change the units on your Withings Body, perform the following steps:

1. Press the button at the back of your Withings Body.
2. Press the button again to change the unit.
Check the screen of your scale to see the unit change.
The unit change is confirmed a few seconds after you stop pressing the button.

Changing the temperature unit

While you can change the weight unit directly from your Withings Body, the temperature unit (used in the Weather screen) can only be changed from the Withings Health Mate® app. To do so, perform the following steps:

1. Open the Withings Health Mate® app.
2. Go to **Settings**.
3. Tap **Units**.

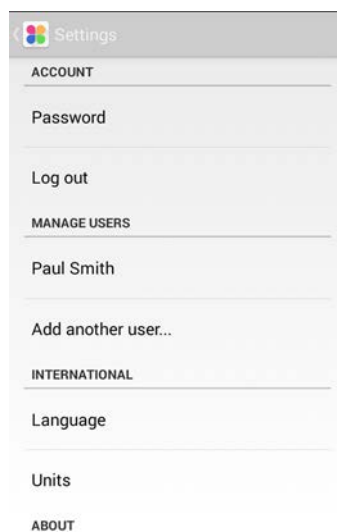

4. Tap **Temperature**.

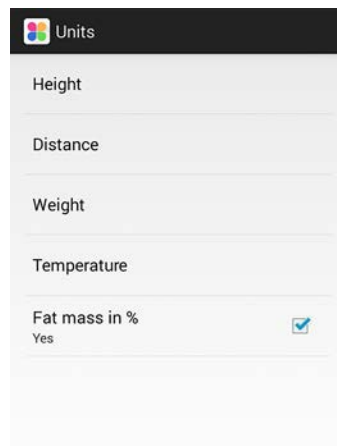

5. Select the temperature unit you want.

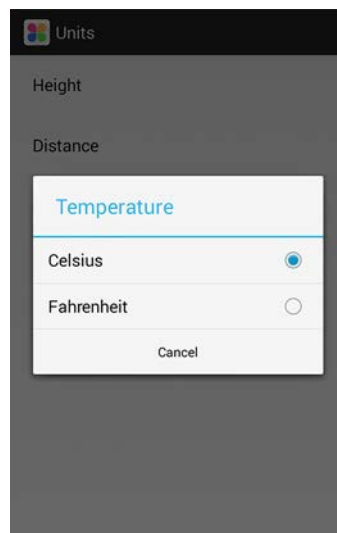

You can also change the weight unit from this screen but it will only affect the display in the Withings Health Mate® app. The weight unit on the Withings Body can only be changed from the scale itself.

6. Tap the back button to confirm.
You will need to weigh in once more before the change is taken into account on your scale.

Changing the screen order

You can change the order of the screens of your Withings Body, for example if you want to display the Weather screen first. To do so, perform the following steps:

1. Open the Withings Health Mate® app.
2. Go to **My devices**.

3. Tap **Body**.



4. Tap **Screens customization**.

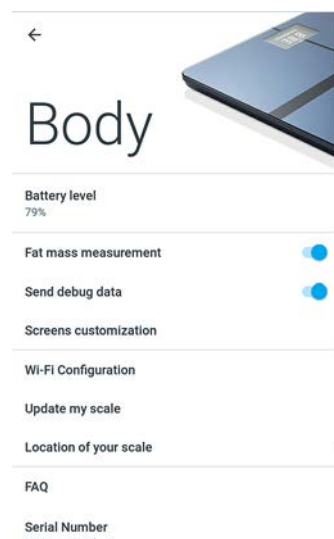

5. Tap the user profile for which you want to change the screen order.

6. Select the screens you want to display:

- Tap the blue circles on the left to hide a screen.
- Tap the empty circles on the left to display a screen.

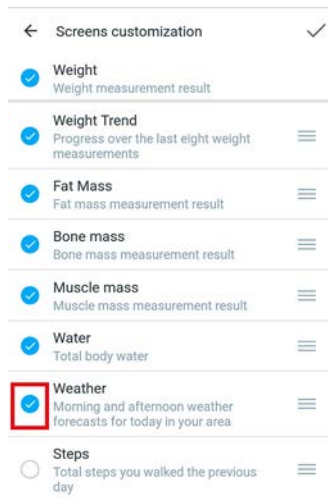

7. Tap and hold the icon on the right to drag a screen up or down.

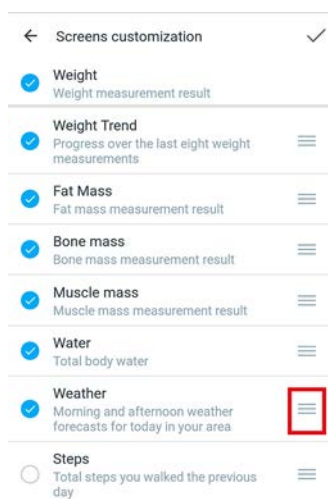

8. Tap the checkmark button in the top right corner to confirm
9. Weigh yourself once to synchronize your Withings Body with your app and finalize the change.
The change will be effective for your next weigh-in.

Changing the location of your scale

The location of your scale is used to provide you with the correct weather forecast if you have activated the Weather screen. It is based on your IP address but it is not always accurate. If the preset location of your scale happens to be incorrect, you are free to change it anytime you want. To do so, perform the following steps:

1. Open the Withings Health Mate® app.
2. Go to **My devices**.
3. Tap **Body**.



4. Tap **Location of your scale**.

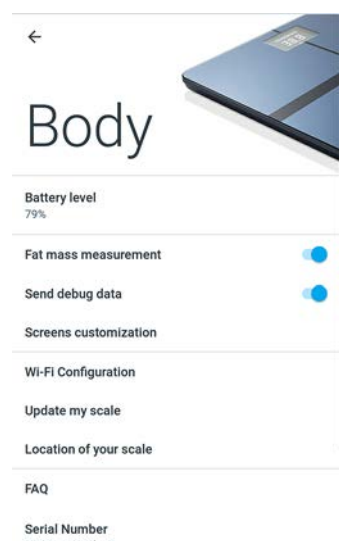

5. Enter the correct location of your scale and tap **OK**.

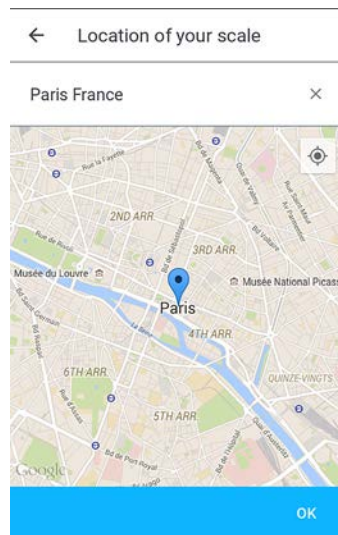

Disabling body composition measurements

You can disable body composition measurements (fat mass, muscle mass, bone mass and water mass) if you choose to. This is recommended for pregnant women and mandatory for anyone wearing a pacemaker.

To disable these measurements, perform the following steps:

1. Open the Withings Health Mate® app.
2. Go to **My devices**.
3. Tap **Body**.



4. Tap **Fat mass measurement**.

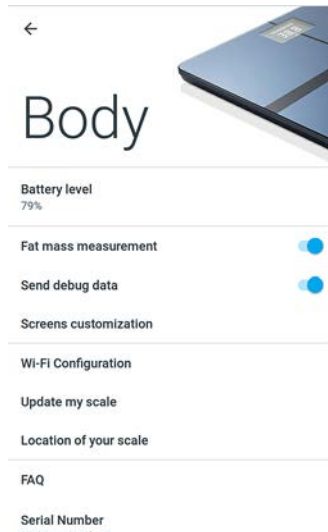

5. Tap the back button to confirm.

Using the Athlete mode

Athletes generally have a different body type which requires a specific fat mass calculation algorithm. If you work out more than 8 hours a week and have a resting heart rate below 60 bpm, you may need to use the Athlete mode. To do so, perform the following steps:

1. Open the Withings Health Mate® app.
2. Go to **Profile**.
3. Tap **User details**.
4. Tap **Edit**.

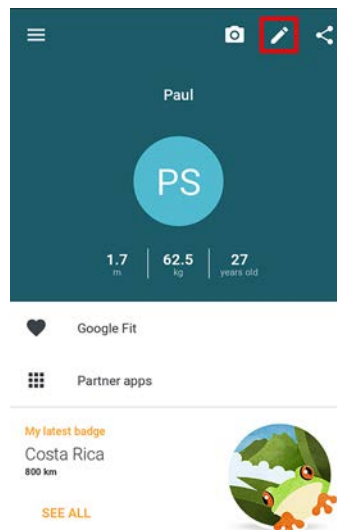



5. Tap **Athlete**.

← Paul Smith

Date of birth
Dec 7, 1987

Email

Height Weight
1.7 m 62.5 kg

Athlete

The "Athlete" mode lets your WS-50 adapt the way it computes fat mass.

SAVE >

6. Tap **Save**.

Using Your Withings Body

Tracking your weight and body composition

Overview

The Withings Body allows you to track your weight and lets you see how your weight trend changes over time. Beside your weight, it also allows you to check your body composition (fat mass, muscle mass, bone mass and water mass) which gives you a better idea of your level of fitness.

Make sure you follow the following recommendations to get accurate and representative weight measurements:

- Make sure you always weigh yourself around the same time to improve the consistency of your measurements.
- Wait five seconds before weighing yourself if you have just moved your scale.
- If your scale is on a carpet, make sure you're using the carpet feet. Refer to ["Installing the carpet feet"](#) on page 45 for more information.

Weighing yourself

Thanks to the Position Control™ technology, getting an accurate weight measurement has never been easier. If your weight is not properly distributed on your Withings Body, arrows are displayed on the scale to indicate in which direction you should lean to stabilize your weight.



If several users have a similar weight, the following screen can be displayed:



Simply lean left or right to select the correct name. Your measurements will then be affected to the correct user.

If you want to get information regarding your body composition as well, make sure that:

- Body composition measurements are enabled. Refer to “Disabling body composition measurements” on page 26 for more information.
- All the body composition screens are enabled. Refer to “Changing the screen order” on page 22 for more information.
- You step on the scale barefoot.
- You stay as still as possible during the measurement.
- You are recognized by your Withings Body, with your name appearing on the screen display.

Retrieving your weight data

As soon as you weigh yourself, your weight is displayed on the display of your scale. If you’ve activated the Weight Trend screen, you’ll also see a graph showing your eight last measurements as well as the difference between the latest measurement and the previous one.

To see detailed graphs about your weight and body composition, and see your full history, you have to check your data on the Withings Health Mate® app.

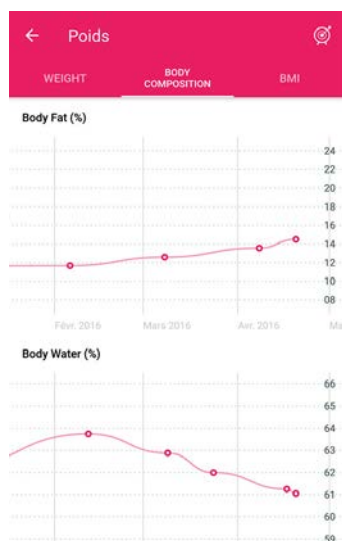

You can access your graphs:

- By tapping the Weight widget at the top of your Timeline.
- By tapping any weight measurement item in your Timeline.

Once you’re viewing the weight graph, you can alternate between the tabs to view your weight graph, your body composition graphs and your BMI graph.

If you need any help interpreting your body composition results, please go to support.withings.com/body/ranges where you’ll find normality ranges for each metric.

Changing your weight goal

To change your weight goal, perform the following steps:

1. Open the Withings Health Mate® app.
2. Tap the right part of the Weight widget.

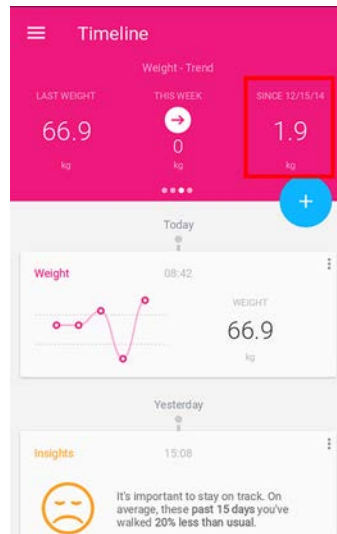

3. Tap and slide up or down to select your target weight.



4. Tap **Next**.

5. Tap and slide up or down to select the pace at which you want to achieve your weight goal.

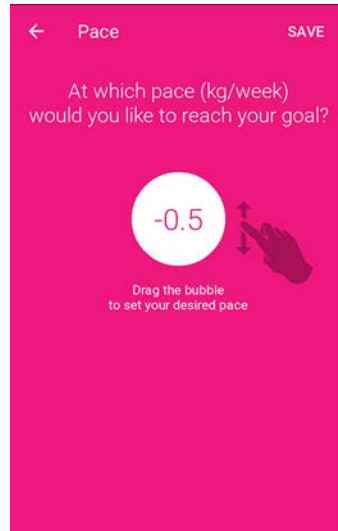

6. Tap **Save**.

Retrieving unknown measurements

If your Withings Body doesn't recognize you when you weigh in, your weight measurements will be listed as unknown measurements. To assign them to a user, perform the following steps:

1. Open the Withings Health Mate® app.
2. Locate **Unknown measures** on the left menu.

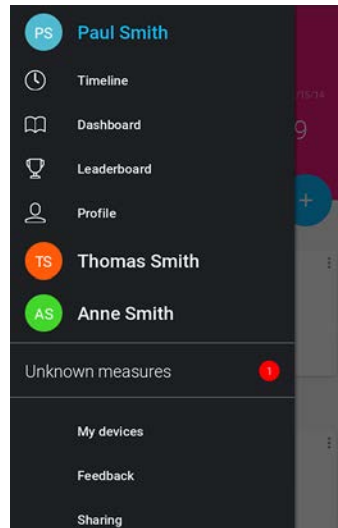

3. Tap the measurement.

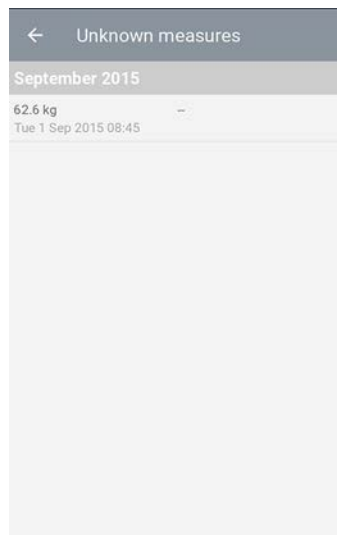

4. Tap **Assign to**.

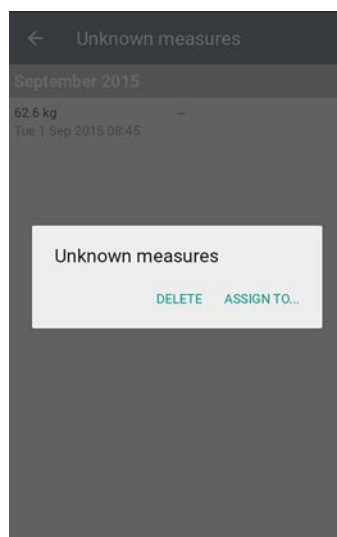

5. Tap the user you want to assign it to.

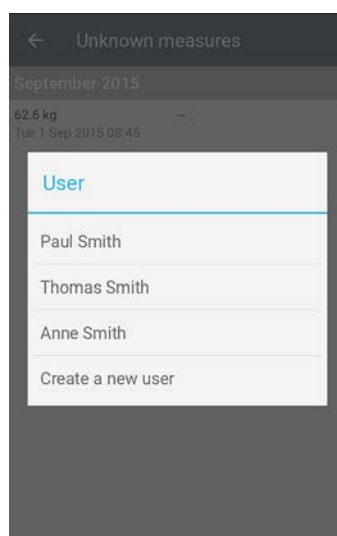

Your measurements are now assigned to the correct user. Your Withings Body will also be able to automatically assign your measurements the next time you weigh in.

Checking the Weather

Overview

You can check the local weather forecast for the day directly on your Withings Body if the following conditions are met:

- Your Withings Body is set up in Wi-Fi. Refer to [“Changing the configuration of your Withings Body” on page 18](#) for more information on how to switch to a Wi-Fi configuration.
- The Weather screen is enabled. Refer to [“Changing the screen order” on page 22](#) for more information.

Retrieving weather information

All you have to do to retrieve weather information on your Withings Body is to step on the scale and wait for the Weather screen to be displayed.

The Weather screen provides you with information about the average weather and temperature for the morning (between 6:00 AM and 12:00 PM) and for the afternoon (between 12:00 PM and 9:00 PM).



If you weigh yourself in the morning, the data of the day is displayed. If you weigh after 7:00 PM, the data of the next day is displayed.

Linking Your Account to Partner Apps

Linking your account to MyFitnessPal

Overview

When you monitor your weight, it can also be useful to monitor your calorie intake with apps such as MyFitnessPal to help you reach your weight goal.

Once you link both accounts, your Withings® account will be able to retrieve your daily calorie intake from MyFitnessPal. You can then check the MyFitnessPal widget from your Dashboard to see your calorie balance.

MyFitnessPal can also retrieve information from your Withings® account: your weight and your calorie outtake.

Your calorie outtake is based on any activity data coming from a Withings® activity tracker or the in-app tracking feature of the Withings Health Mate® app. Note that tracking your activity can be a great way to help you achieve your weight goal.

Connecting to MyFitnessPal

To connect your Withings® account to your MyFitnessPal account, perform the following steps:

1. Open the Withings Health Mate® app.
2. Tap **Profile**.
3. Tap **Partner apps**.

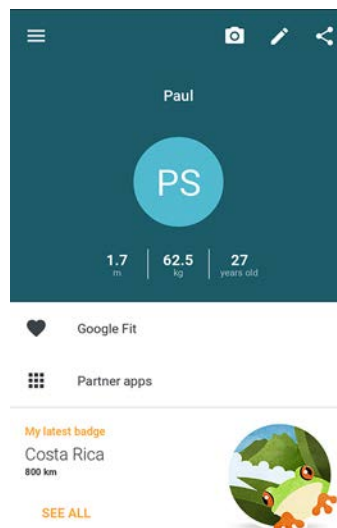

4. Tap **Connect** under **MyFitnessPal**.

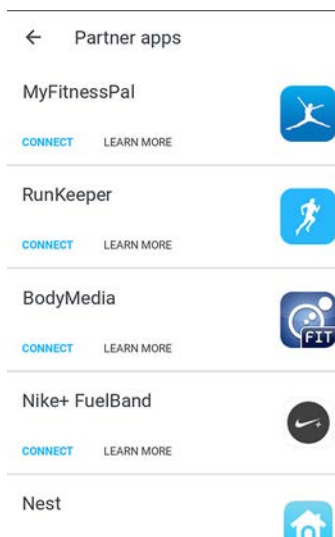

5. Tap **OK**.



6. Log in to your MyFitnessPal account.

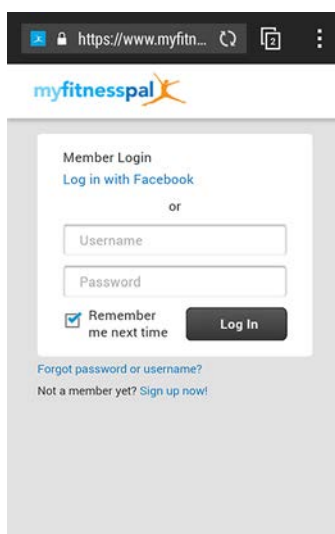

7. Tap **OK**.

You can unlink your MyFitnessPal account and your Withings® account anytime you want from your Profile.

Linking your account to Nike+

Overview

If you have a Nike+ account, you can start the day by seeing your NikeFuel of the previous day displayed on your Withings Body and in the Withings Health Mate® app thanks to the Nike+ integration.

Only your NikeFuels can be shared with your Withings account. You'll have to stick to the Nike+ app to see the rest of your Nike+ data.

Note that it can take up to 48 hours after the association for your data to be shared with your Withings® account. You also need to have at least 5 days worth of Nike+ data before it can be shared with your Withings® account.

Connecting to Nike+

To connect your Withings® account to your Nike+ account, perform the following steps:

1. Open the Withings Health Mate® app.
2. Tap **Profile**.
3. Tap **Partner apps**.

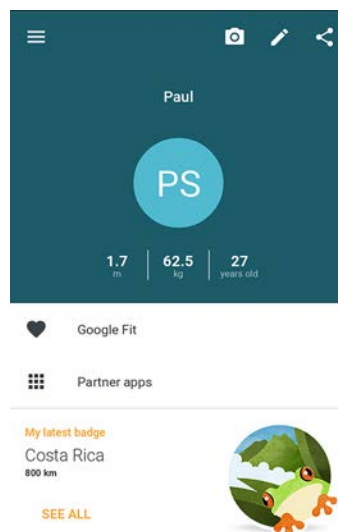

4. Tap **Connect** under **Nike+ FuelBand**.

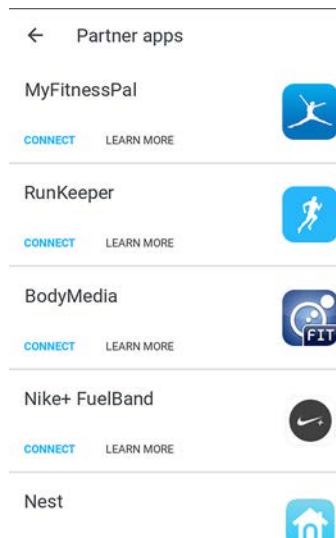

5. Tap **Link with Nike+ FuelBand**.



6. Log in to your Nike+ account.

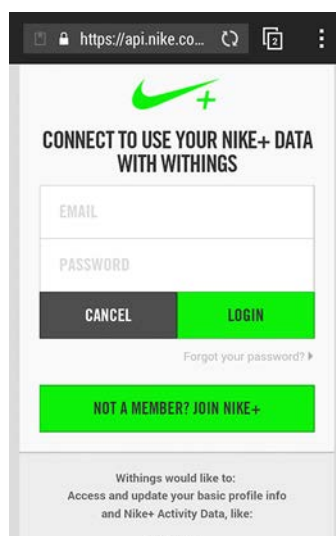

Note that it can take up to 48 hours after the association for your data to be shared with your Withings® account.

You can unlink your Nike+ account and your Withings® account anytime you want from your Profile.

Syncing Your Data

Data from your Withings Body is automatically synced, without any action required on your part. Your weight data is synced with the Withings Health Mate® app within a few minutes after you weigh in.

Dissociating Your Withings Body



All data that wasn't synced before dissociating your Withings Body will be lost permanently.

Dissociating your Withings Body allows you to remove it from your account.



Dissociating your Withings Body will not remove any of the data that was synced from the Withings Health Mate® app.

To dissociate your Withings Body, perform the following steps:

1. Open the Withings Health Mate® app.
2. Go to **My devices**.
3. Tap **Body**.



4. Tap **Dissociate this product**.

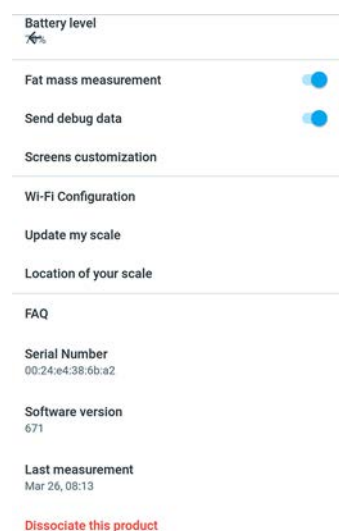

5. Tap **Remove from my account**.

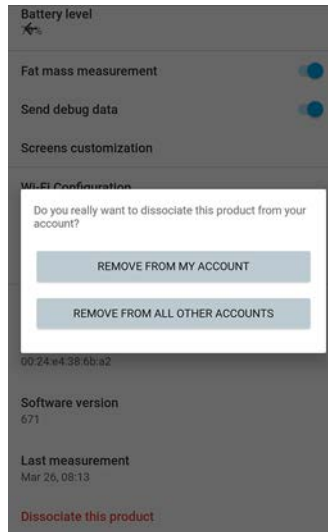

6. Perform a factory reset of your Withings Body. Refer to [“Performing a Factory Reset of Your Withings Body”](#) on page 43 for more information.

Performing a Factory Reset of Your Withings Body



All data that wasn't synced before factory resetting your Withings Body will be lost permanently.

Factory resetting your Withings Body allows you to delete the data stored on it. Factory resetting completes the dissociation process.



Factory resetting your Withings Body will not remove any of the data from the Withings Health Mate® app.

1. Go to the Bluetooth settings of your device and “forget” your Withings Body from the list of Bluetooth devices.
2. Remove one of the batteries for ten seconds.
3. Put the battery back.
4. When “Hello” appears on the display of your scale, press and hold the button at the back of the scale until the factory reset gauge fills.
The scale's screen will display the word “Factory”, confirming the reset.

At this time, you can start the installation process for the Withings Body. Refer to [“Setting Up the Withings Body” on page 7](#) for more information.

Cleaning and Maintenance

Cleaning your Withings Body

You can clean your Withings Body using a cloth dampened with water. If water is not enough to clean it, you can also use crystal vinegar.



The use of any detergents or cleaners may cause irreversible damage to the coating that protects the electrodes used to measure your body composition.

Changing the batteries

Your Withings Body uses four standard AAA batteries and has an autonomy of 8 months. To check the battery level of your Withings Body, perform the following steps:

1. Open the Withings Health Mate® app.
2. Go to **My devices**.
3. Tap **Body**.



4. Check the battery level displayed at the top.

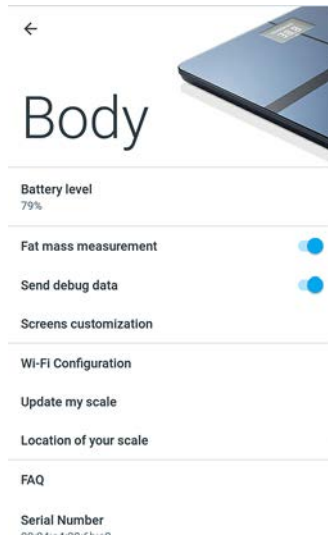

If the battery level is below 20% and you're having syncing issues, we advise that you change the batteries.

Installing the carpet feet

If you are using your Withings Body on a carpet, we recommend that you use the carpet feet included with your scale. To do so, perform the following steps:

1. Remove the tab below each carpet foot.

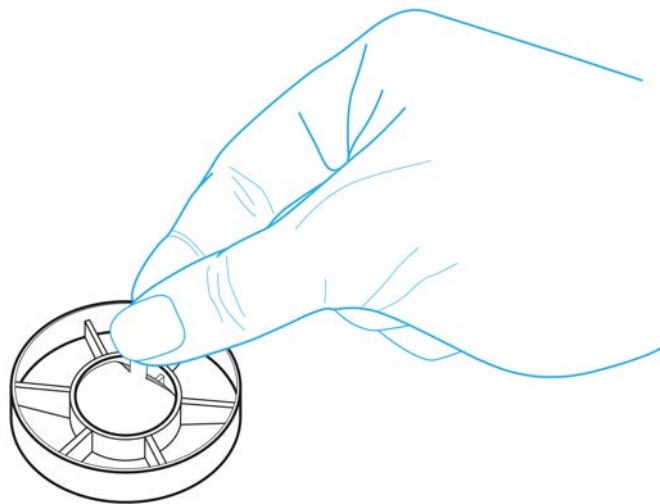

2. Stick each carpet foot on the Withings Body feet.

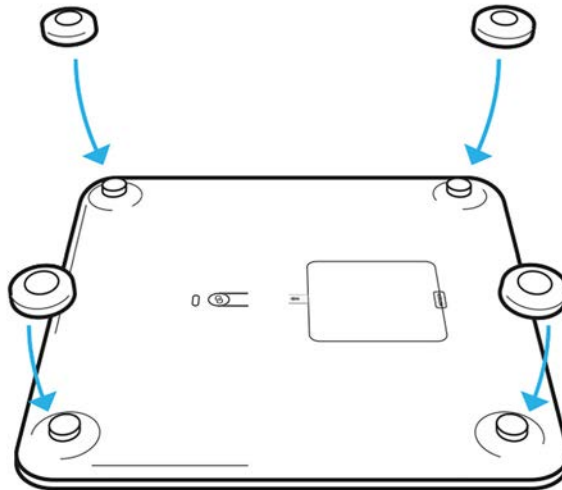

Updating your Withings Body

We regularly offer updates so that you can benefit from the latest features we add to our products. When new internal software is available, it is automatically installed without any prompt from the Withings Health Mate® app if your scale is installed in Wi-Fi.

However, you can check if updates are available and force their installation whenever you want. To do so, perform the following steps:

1. In the Withings Health Mate® app, go to **My devices**.
2. Tap **Body**.



3. Tap **Update my scale**.

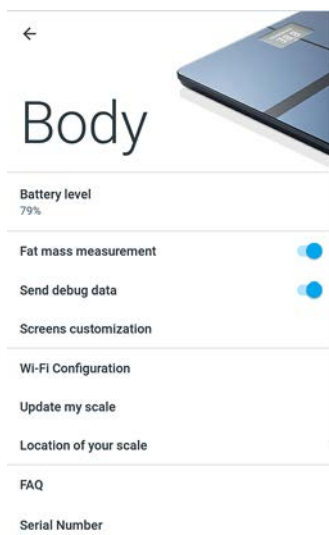

4. Press the pairing button at the back of the scale and tap **Next**.

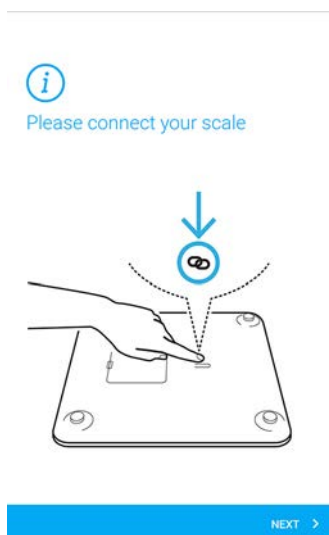

5. Tap the Withings Body you want to update.

6. Tap **Upgrade**.

7. Tap **Close** when the upgrade is complete.

Note: You can check which software version your Withings Body uses in **My devices > Body**.

Technology Description

Weight

Your weight is measured thanks to four weight sensors placed below the surface of your Withings Body.

Body Composition

Your body composition (fat mass and water percentage, muscle mass, and bone mass) is measured by bioelectrical impedance analysis thanks to electrodes placed below the surface of your Withings Body. These electrodes send a small current that goes through your body, and then analyse the way your body reacts to measure these metrics.

Specifications

Withings Body

- Length: 325 mm (12.8")
- Width: 325 mm (12.8")
- Depth: 23 mm (0.90")
- Weight: 2.1 kg (4.6 lbs)
- Weight range: 5 kg - 180 kg (9 lbs - 396 lbs)
- Weight units: kg, lb, stlb
- Precision: 100 g (0.2 lbs)

Display

- 6.1 cm x 4.1 cm (2.4" x 1.6")
- 128 x 64 pixels
- Backlighting

Connectivity

- Wi-Fi 802.11 b/g/n (2,4 GHz only)
- Bluetooth / Bluetooth Low Energy (Bluetooth Smart Ready)

Sensors

- 4 weight sensors
- Position Control™ technology

Metrics

- Weight
- Fat mass (%) - standard and athlete mode
- Muscle mass (kg)
- Bone mass (kg)
- Water mass (%)

Batteries

- 8 months autonomy
- 4 AAA batteries

Features

- Automatic user recognition
- Weather forecast

Compatible Devices

- iPhone 4s (or higher)
- iPod Touch 4th Gen (or higher)

- iPad 2nd Gen (or higher)
- Bluetooth Low Energy compatible Android device

Compatible OS

- iOS 8.0 (or higher)
- Android 2.3.3 (or higher)

User Guide Copyright

This User Guide is protected by Intellectual Property laws and copyright. Any reproduction, modification, representation, and/or publication without Withings® prior approval is strictly prohibited. You may print this User Guide for your personal use exclusively. For any questions, please contact Withings at: <http://contact.withings.com>.

Safety Instructions



By using your Withings Body you expressly agree to the Withings Services Terms and Conditions available on our [website](#).

This product is not a medical device and should not be used to diagnose or treat any medical condition.

This product should not be used by people wearing a pacemaker or any other internal medical device

Use and Storage

- Use the product at temperatures between 5°C and 35°C (41°F and 95°F) with a relative humidity between 30% and 80%.
- Product may be stored in a clean location between -10°C and 50°C (14°F and 122°F) when it is not in use, with a relative humidity between 10% and 90%.
- This product is not a toy. Do not allow children to play with it.
- This device is designed for indoor use only.
- Do not allow the device to come in contact with liquids.
- Do not use any detergents or cleaners to clean the scale. They may cause irreversible damage to the coating that protects the electrodes used to measure your body composition.

Location

- Do not use your Withings Body in a place that is too humid as it can affect the batteries.
- Make sure you use the carpet feet if you place your Withings Body on a carpet.

Personal Data

- Make sure you have read our privacy policy, which you can find on our [website](#).
- Make sure your Withings® account password is secure enough to restrict access to your account. It should be at least eight-character long, have mixed case, and use a combination of alphanumeric and special characters.

- We recommend that you export your data on a regular basis to local storage on your home computer. You can do so from the Withings Health Mate® [web interface](#) by clicking **Measurement table**, selecting the tab corresponding to the data you want to export and clicking **Download**.

Service and Maintenance

- Do not attempt to repair or modify your Withings Body yourself. Service and maintenance not described in this User Guide should be performed by professional technicians.
- If you have any issues, feel free to contact customer service at: <http://contact.withings.com>.

Document Release Overview

Release date		Modifications
May 2016	v1.0	First release



The screenshots in this manual are used for explanatory purposes. Your actual screens may differ from the screenshots in this manual.

Warranty

Withings® One (1) Year Limited Warranty - Withings Body

Withings® warrants the Withings® branded hardware product (“Withings Body”) against defects in materials and workmanship when used normally in accordance with Withings®’ published guidelines for a period of ONE (1) YEAR from the date of original retail purchase by the end-user purchaser (“Warranty Period”). Withings®’ published guidelines include but are not limited to information contained in technical specifications, safety instructions, or quick start guide. Withings does not warrant that the operation of the Withings Body will be uninterrupted or error-free. Withings® is not responsible for damage arising from failure to follow instructions relating to the Withings Body’s use.

The warranty does not extend to:

- Any damage to the device resulting from abnormal or abusive use, negligence or lack of care, or accidental damage (such as dents).
- Indirect damages of any kind.

Regulatory Statements

FCC ID: XNAWBS05

This device complies with Part 15 of the FCC Rules.

Operation is subject to the following two conditions: (1) This device may not cause harmful interference, and (2) This device must accept any interference received, including interference that may cause undesired operation.

This device complies with the R&TTE Directive. A copy of the EU Declaration of Conformity is available online at <http://www.withings.com/compliance>