

# SÉRIE 966

0.005 ... 30 Nm

Couplemètre vendu séparément  
Torquemeter sold separately

- Faible poids et inertie
  - Grande rigidité torsionnelle
  - Accouplement simple, montage flottant
  - Pour arbre lisse et claveté
  - Permettent de conserver toutes les caractéristiques de nos couplemètres
- *Low weight and inertia*
  - *Very high torsional rigidity*
  - *Simple coupling, free floating assembly*
  - *For shaft with and without keyway*
  - *These couplings maintain all the specifications of our torque meters*

## Pour couplemètre - For torque meter:



DR2



DR20 / DR2513

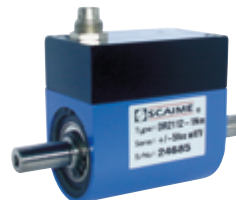

SÉRIE DR2112



DR2208

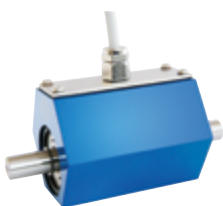

DR2477



DR2643



DR2500



D2452

## Information de commande - Order information:

**966(-P) (-PP) Gr    B    -    C    -    D**

Exemple : **966 Gr50-8-12 / 966-P Gr37-8P-12 / 966-PP Gr62-10P-20P**

- P : Pour couplemètre **ou** axe client claveté (DIN 6885) - For one coupling side with feather key (DIN 6885)
- PP : Pour couplemètre **et** axe client claveté (DIN 6885) - For torque meter and shaft customer with feather key
- B : Taille de l'accouplement - Coupling size
- C : Ø arbre couplemètre - Ø torque meter shaft
- D : Ø arbre client - Ø customer shaft

# SÉRIE 966

0.005 ... 30 Nm

**Pour montage couplemètre flottant - For free floating torque sensor assembly**

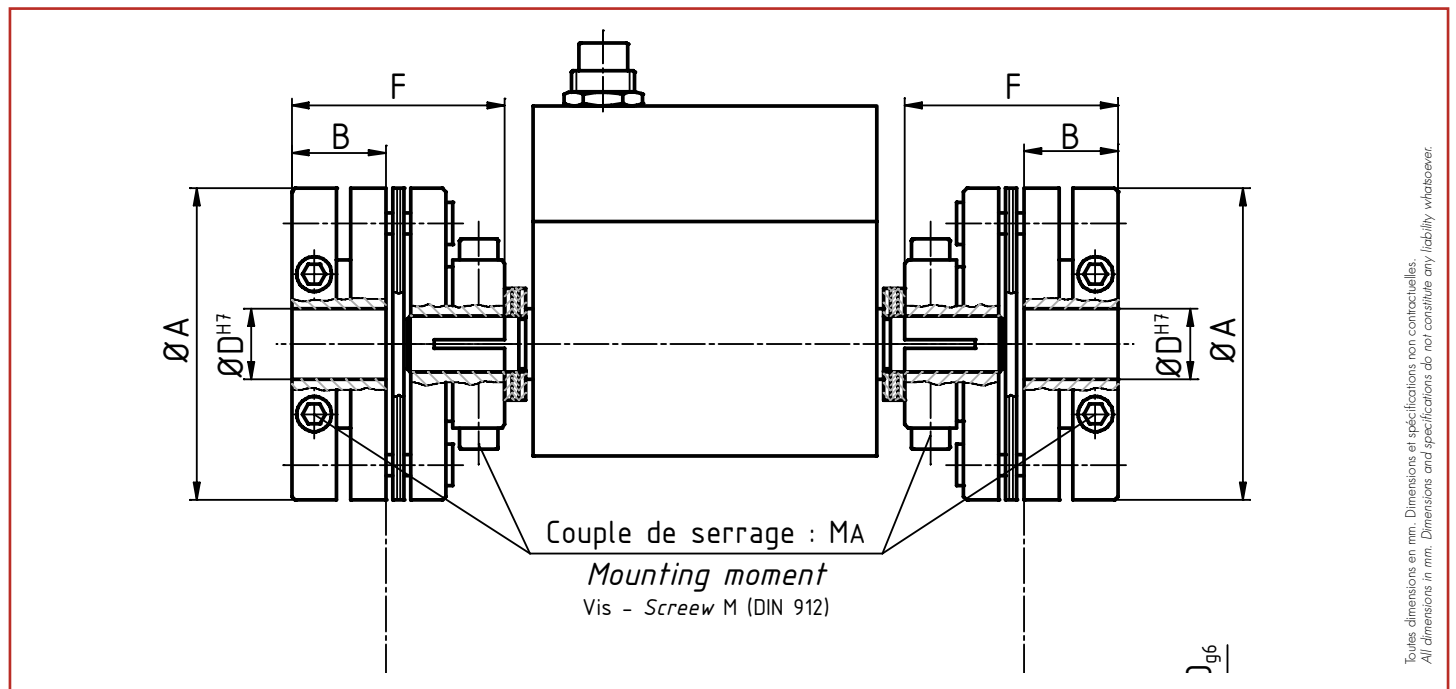
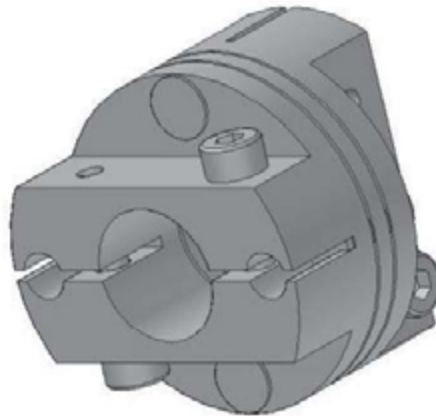

Taille (Gr) Coupling size	Couple Nominal Nominal Torque [Nm]		Vitesse max. accouplement Limit speed coupling [min <sup>-1</sup> ]	Dimensions - Dimension [mm]					M <sub>A</sub> [Nm]	
	Couplemètre Sensor	Accouplement Coupling		ØA	B	ØD <sup>1</sup>		F		M
						axe lisse - shaft without feather key	axe claveté - shaft + feather key			
18	0.005, 0.01, 0.02, 0.05	0.2	100 000	19.1	7	3 ... 7	-	15.6	M2.5	0.7
25	0.1, 0.2	0.4	80 000	25.4	9	3 ... 10	-	20.2	M3	1.3
37	0.5, 1	1.6	55 000	35.8	13.2	4 ... 14	4 ... 12	29.1	M4	3
50	2, 5	6.2	45 000	44.5	13.4	6 ... 18	6 ... 1	30.4	M5	5.9
62	10, 20	24.7	35 000	57.4	16.1	8 ... 24	8 ... 22	36.6	M6	10.1
75	30	36.2	30 000	64	18	8 ... 28	8 ... 23	41	M6	10.1

1. Spécifier le diamètre (nombre entier) de l'axe à la commande - Please specify requested Ø (without decimal) at order



Siège Social - Headquarter: Technosite Altéa - 294, Rue Georges Charpak - 74100 JUVIGNY - FRANCE  
SCAIME SAS - 294, RUE GEORGES CHARPAK - CS 50501 - 74105 ANNEMASSE CEDEX - FRANCE  
Tél. : +33 (0)4 50 87 78 64 - Fax : +33 (0)4 50 87 78 46 - info@scaime.com - [www.scaime.com](http://www.scaime.com)  
Téléchargez tous nos documents sur notre site internet - Download all our documents on our website